

EMF Vehicle Stacker

the quick way to double your parking space

The Stacker is a parking lift available in two or four post models. It has a lifting capacity of 2700 kg or 3000 kg depending on the model.

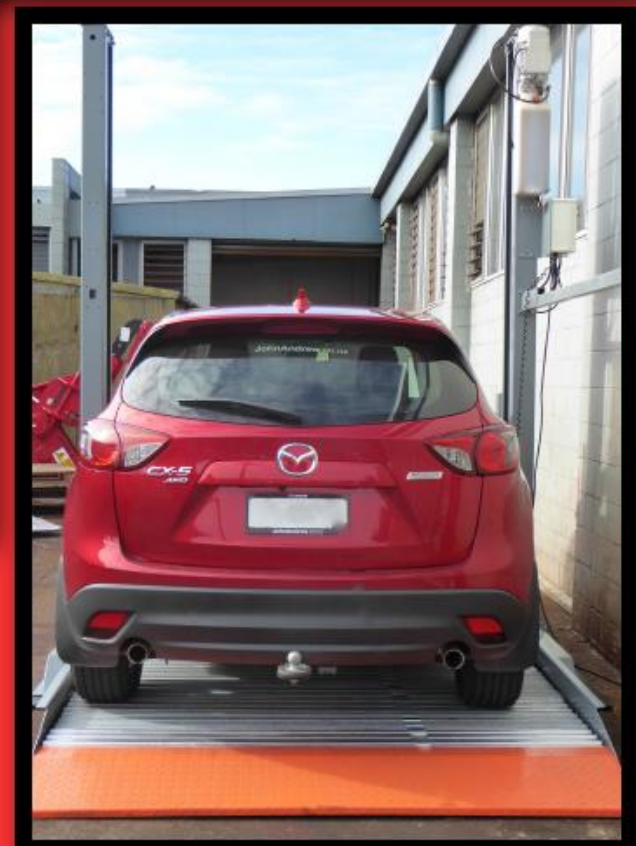

The Stacker is constructed from galvanised, formed steel. It is driven by a single phase electric motor which powers dual hydraulic lifting cylinders.



Multiple two post units can be connected together sharing the middle post.

Safety features include:
 -hydraulic overloading protection
 -dynamic mechanical anti-falling locks
 -automatic shut-off if key is released
 -photocell sensor to prevent lowering onto parked car

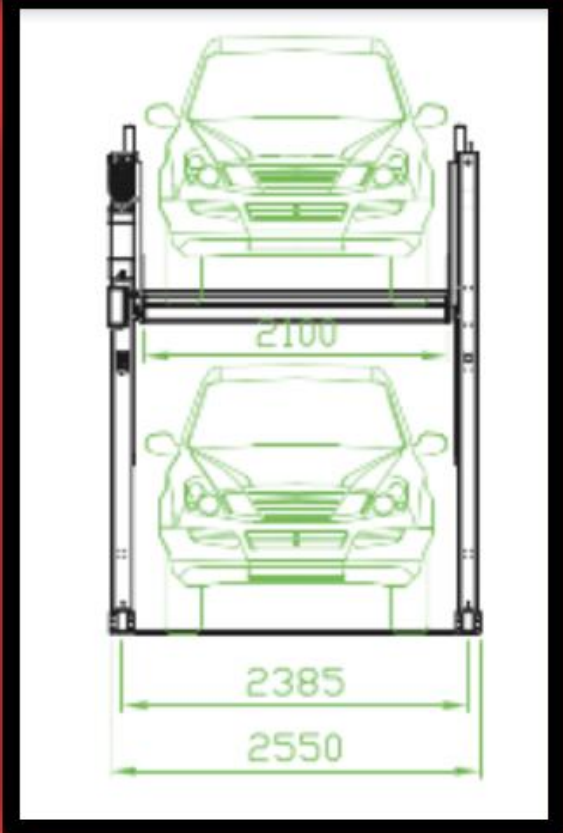
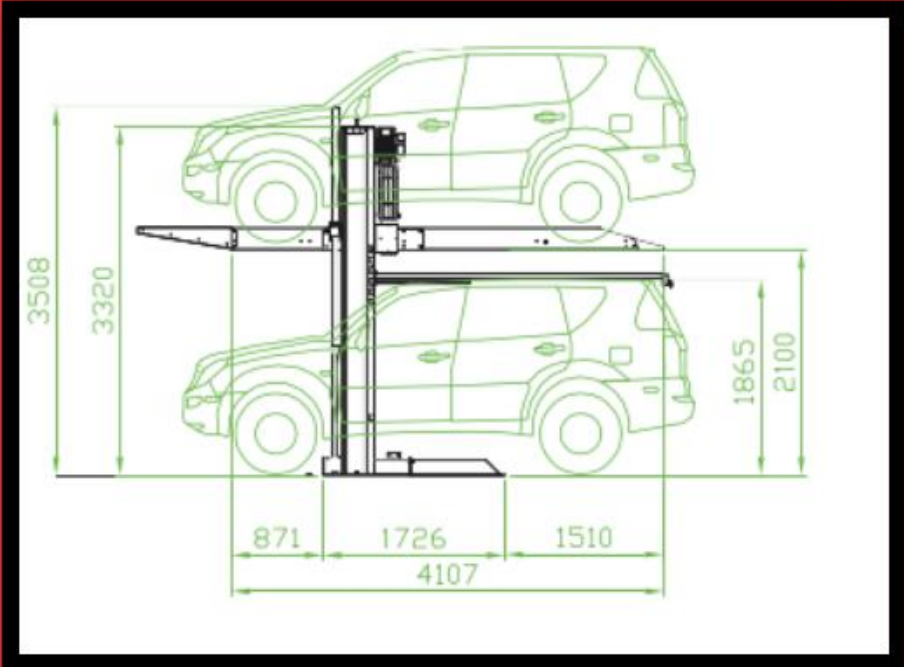

Electro-Mechanical Fabrications
 Contact Peter Gill 09 836 4149 office@emf.co.nz
 www.emf.co.nz